

© COPYRIGHT OF THIS DRAWING IS RESERVED BY DBFL CONSULTING ENGINEERS. NO PART SHALL BE REPRODUCED OR TRANSMITTED WITHOUT THEIR WRITTEN PERMISSION.

NO CHANGES OF WHATSOEVER NATURE ARE TO BE MADE TO ANY DETAILS SET OUT OR CONTAINED IN ANY DBFL SPECIFICATIONS OR DRAWINGS UNLESS THE EXPRESS CONSENT HAS BEEN OBTAINED IN ADVANCE, IN WRITING, FROM DBFL.

NOTES:

- THIS DRAWING IS TO BE READ IN CONJUNCTION WITH ALL RELEVANT ARCHITECTS AND ENGINEERS DRAWINGS AND SPECIFICATIONS.
- ALL EXCAVATIONS FOR FOUNDATIONS TO BE INSPECTED BY A CHARTERED REGISTERED PROFESSIONAL AT CONSTRUCTION STAGE.
- FOUNDATION WIDTHS AND DEPTH WILL VARY TO SUIT GROUND CONDITIONS ON SITE AS THEY ARE ENCOUNTERED DURING CONSTRUCTION AND SUBJECT TO DETAILED DESIGN.

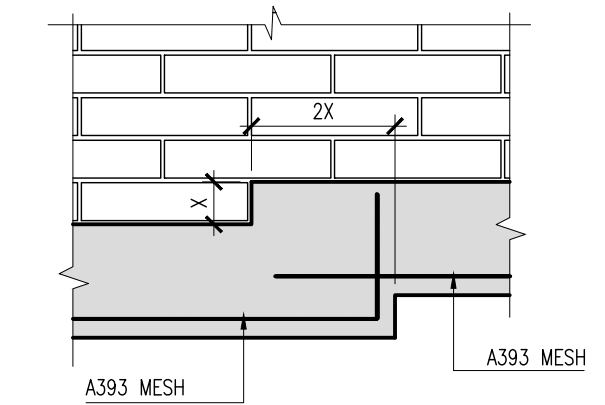

TYPICAL FOUNDATION STEP DETAIL (1:20)

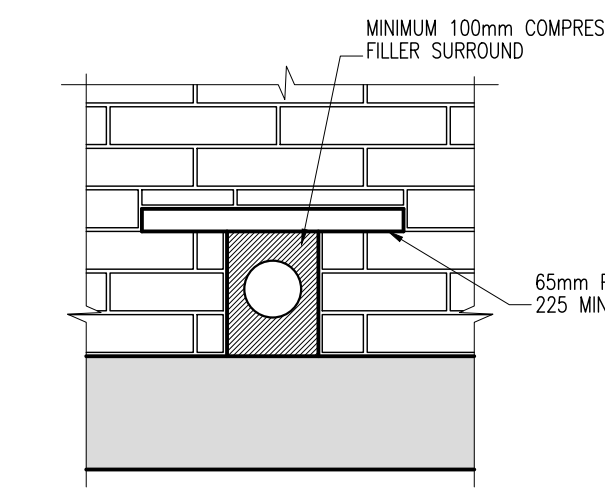

SERVICES ABOVE FOUNDATIONS (1:20)

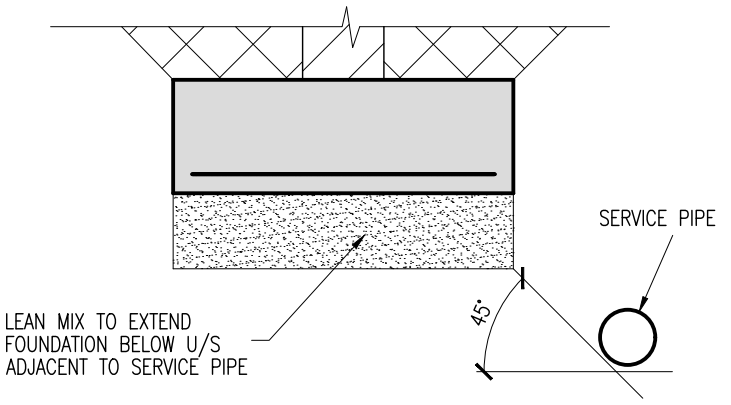

SERVICES ADJACENT TO FOUNDATIONS (1:20)

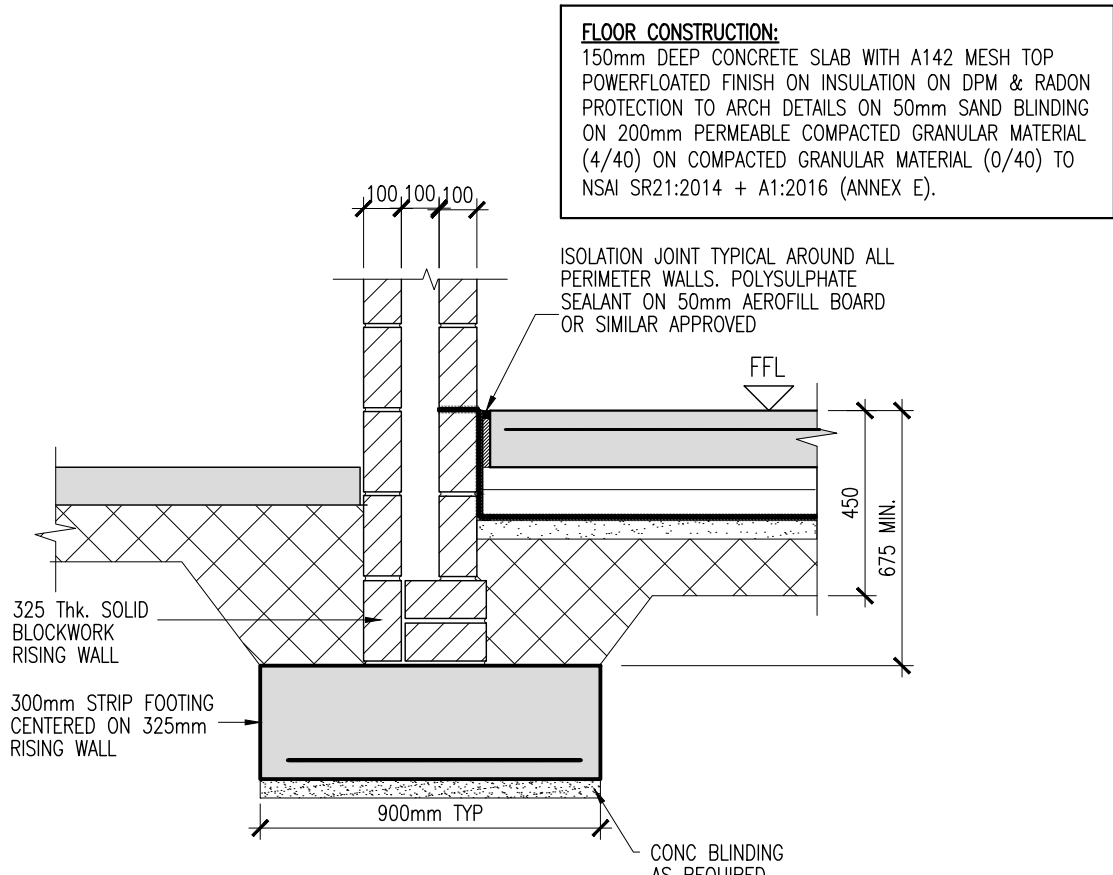

TYPICAL HOUSE FOUNDATION DETAIL 1 (1:20)

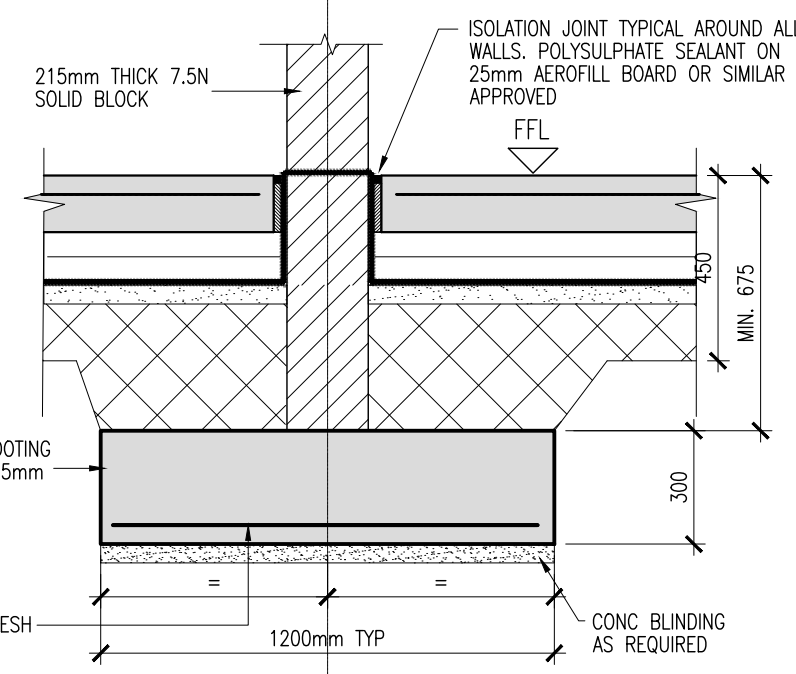

TYPICAL HOUSE FOUNDATION DETAIL 2 (1:20)

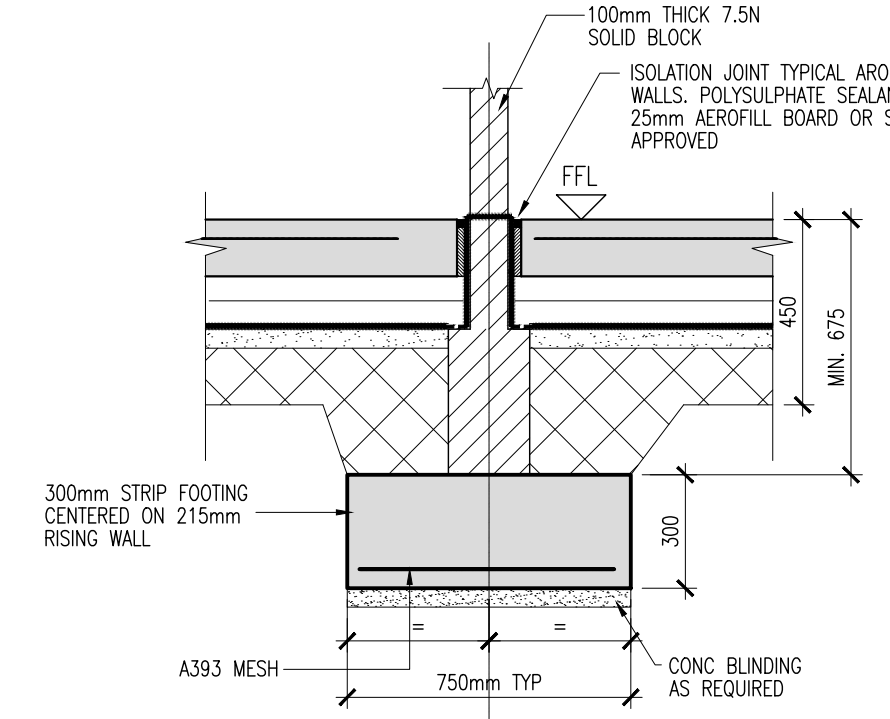

TYPICAL HOUSE FOUNDATION DETAIL 3 (1:20)

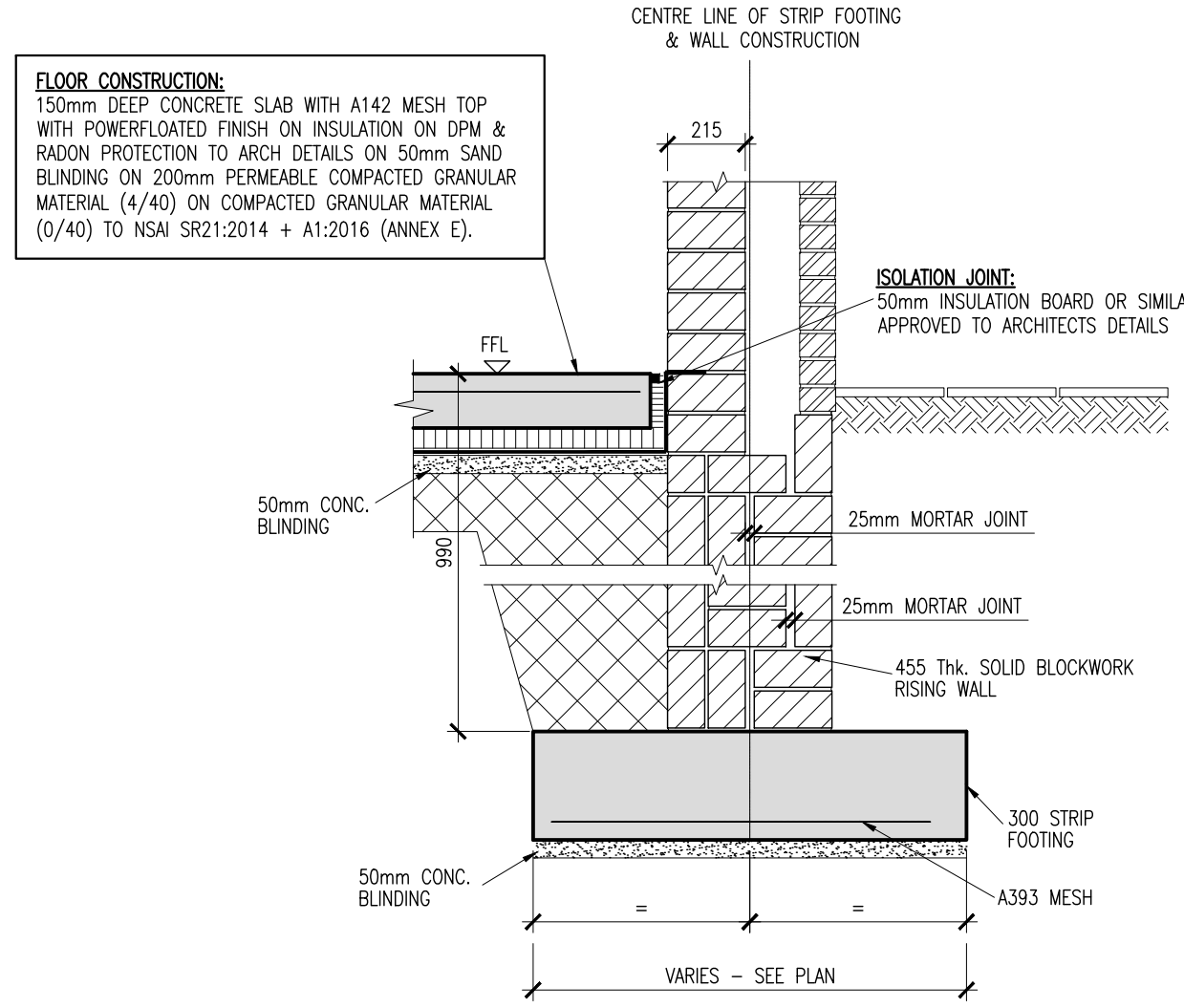

TYPICAL APARTMENT FOUNDATION SECTION 1 (1:20)

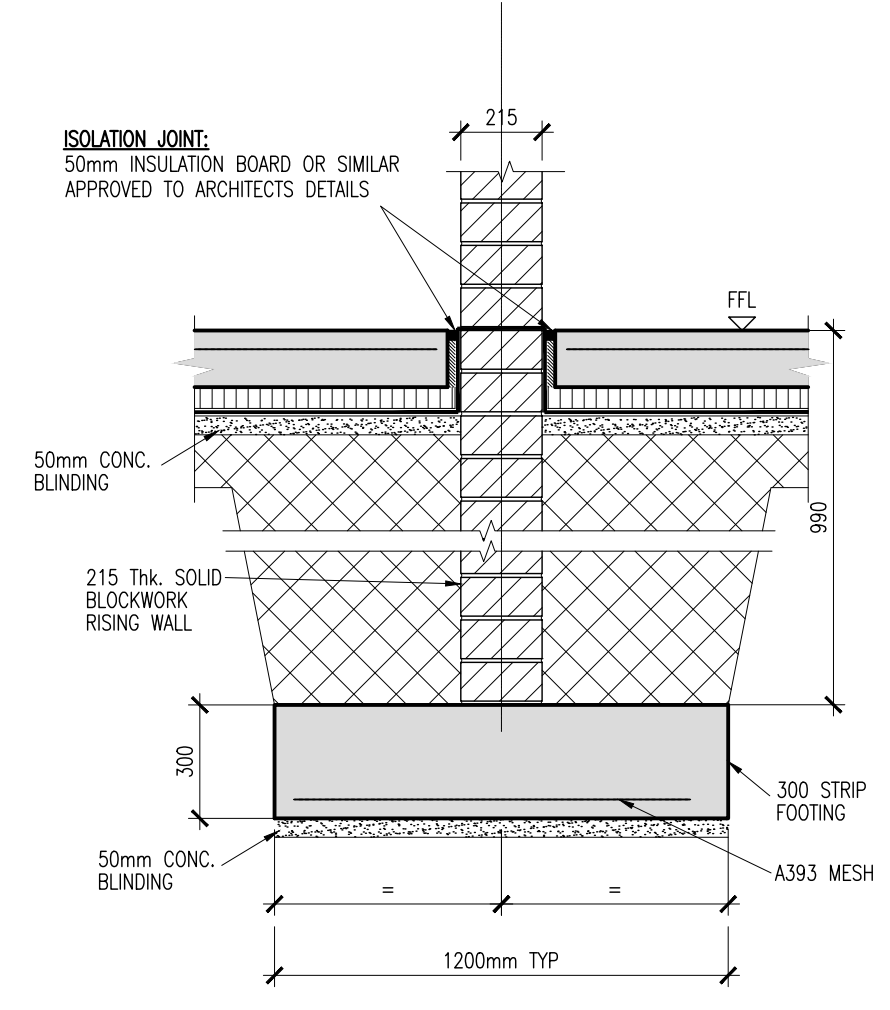

TYPICAL APARTMENT FOUNDATION SECTION 2 (1:20)

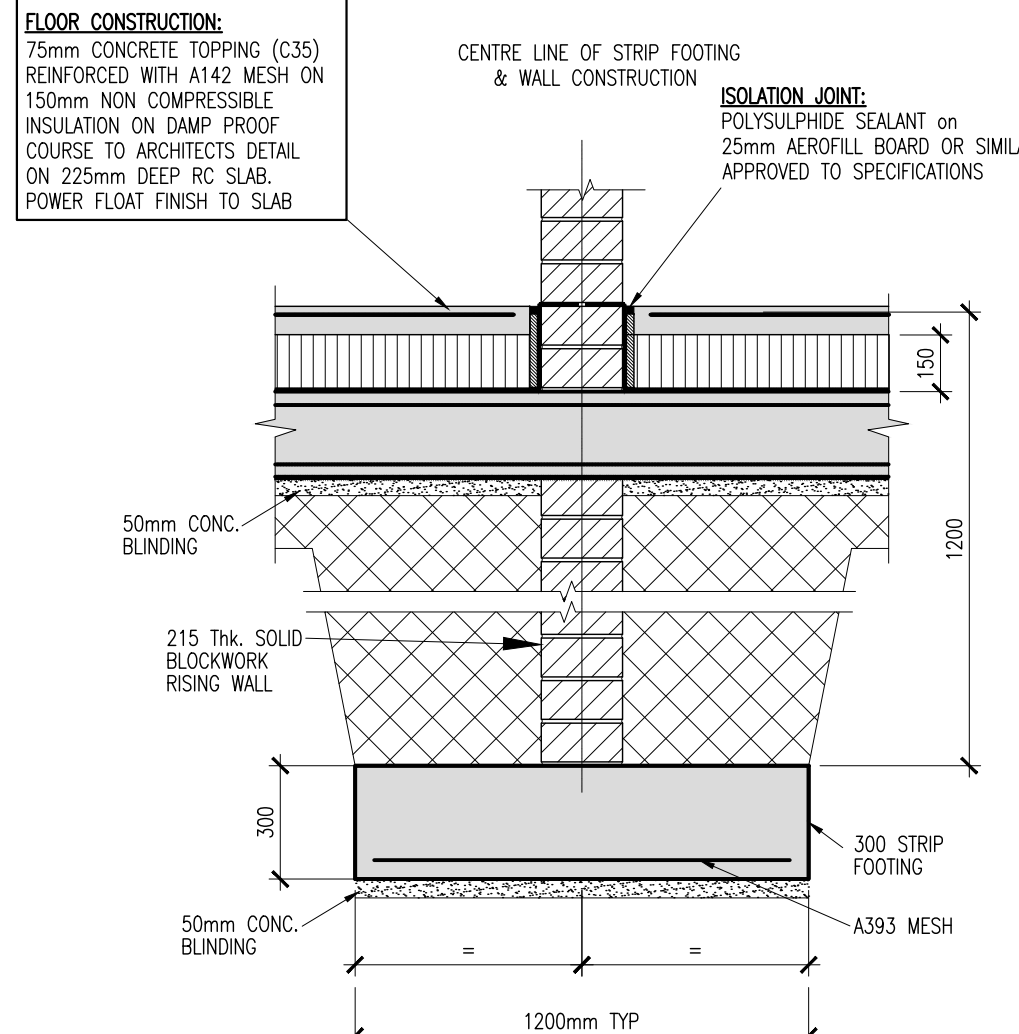

TYPICAL APARTMENT FOUNDATION SECTION 6 (1:20)

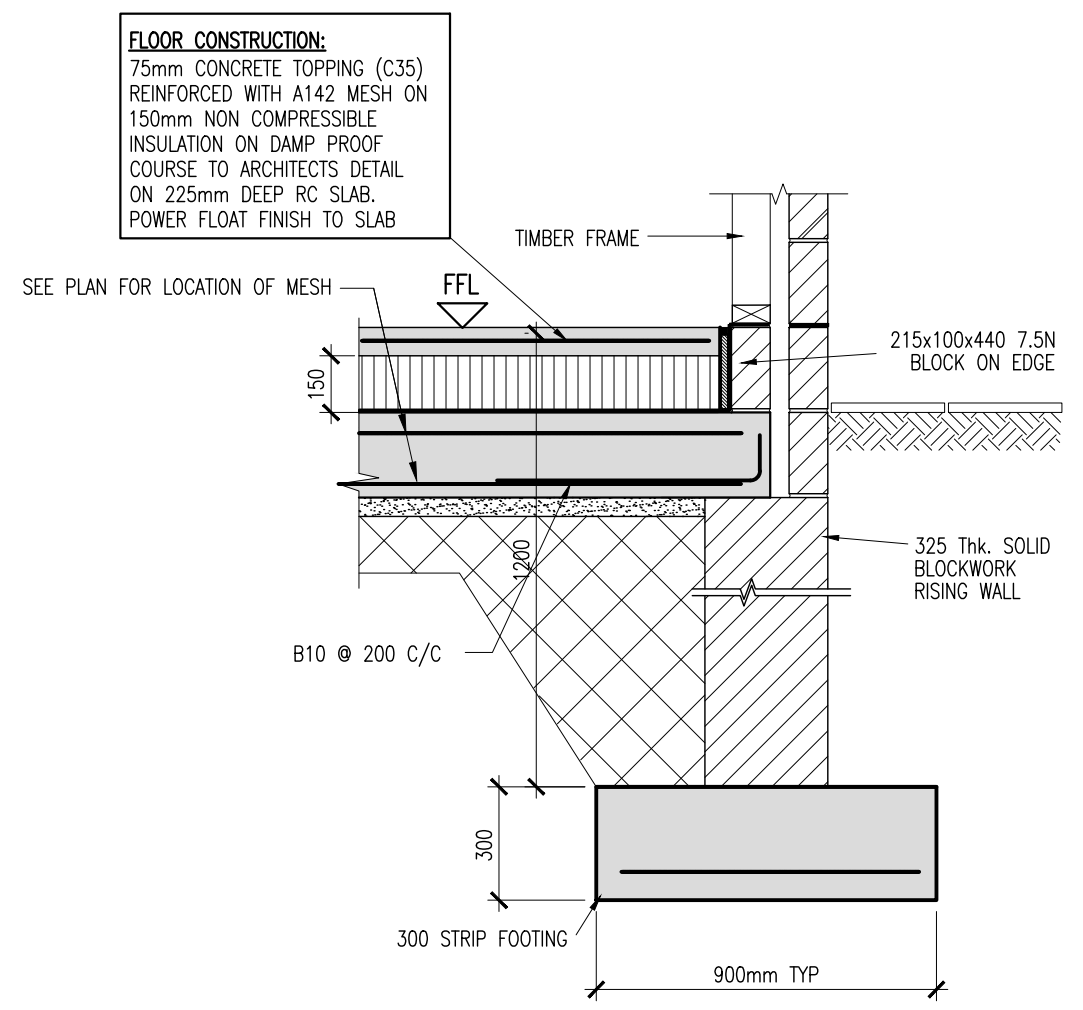

TYPICAL APARTMENT FOUNDATION SECTION 7 (1:20)

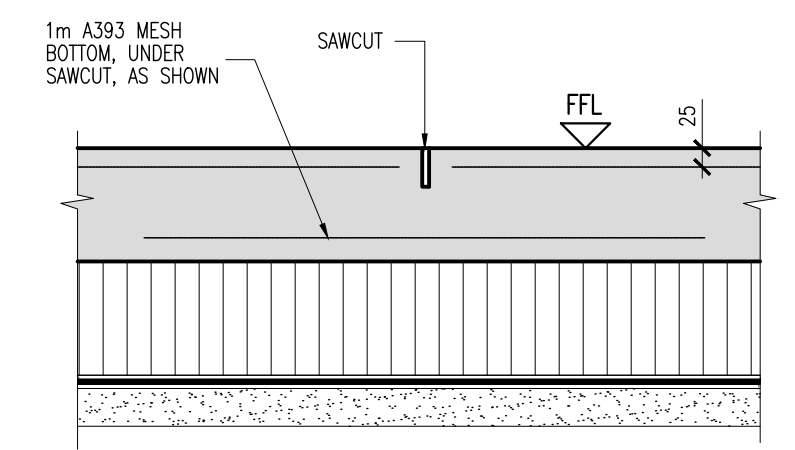

SAWCUT DETAIL (CJ)
(Scale 1:10)

ORDNANCE SURVEY IRELAND LICENCE
No EN 0017922
© ORDNANCE SURVEY IRELAND
GOVERNMENT OF IRELAND

P01	09-06-22	PLANNING SUBMISSION	ICJ	NOH
rev	date	description	by	chkd.
		A - Approved		
		B - Approved with comments		
		C - Do not use		

S4 - STAGE APPROVAL PLANNING

DBFL Consulting Engineers
Civil, Structural & Transportation Engineering
www.dbfl.ie

DUBLIN OFFICE: Ormond House, Upper Ormond Quay, Dublin 7, D07 W704
PHONE +353 1 454 4000

CORK OFFICE: 14 South Mall, Cork, T12 CT91
PHONE +353 21 2024538

WATERFORD OFFICE: Suite 10 The Atrium, Maritime Gate, Canada Street, Waterford, X91 WC08
PHONE +353 51 309 500

project ref.
**BALLYOULSTER KDA SHD - PHASE 1
RESIDENTIAL DEVELOPMENT**

drawing title
**TYPICAL FOUNDATION DETAILS
SHEET 3**

client
**KIERAN CURTIN, RECEIVER OVER
CERTAIN ASSETS OF MAPLEWOOD
DEVELOPMENTS UNLIMITED COMPANY**

designed by	author	scale	sheet size
NOH	ICJ	AS SHOWN	A1
drawing no.		revision	
180221-DBFL-RD-SP-DR-C-5103		P01	